

Dynamatic®

DRIVE SOURCE INTERNATIONAL, INC.

Instruction Manual

Model 3000 Controller 90 VDC





Please Observe The Following Safety Guidelines

Allow Installation and Service by Qualified Personnel Only

Electrical rotating equipment and associated controls can be dangerous. Therefore, it is essential that only trained personnel be allowed to work with this equipment, under competent supervision. The danger is increased when the equipment is not handled, installed, maintained or used properly. This equipment must be installed, adjusted and serviced only by qualified personnel familiar with the construction and operation of the equipment and the hazards involved. Failure to observe this precaution could result in personal injury and/or equipment damage.

Read Instructions and Warnings

These instructions should be read and clearly understood before working on the equipment. Become especially familiar with all safety instructions and procedures. Read and heed all danger, warning and caution notices contained in this manual and attached to the equipment and be sure to instruct others in their meaning and importance.

Danger, High Voltage

Disconnect Power Before Servicing Equipment

Various component parts and terminals of the drive equipment are at or above line voltage when AC power is connected to the input terminals. All ungrounded conductors of the AC power line must be disconnected before it is safe to touch any internal parts of this equipment. Some control equipment may contain capacitors that retain a hazardous electrical charge for a period of time after power is removed. After power is removed, wait at least two minutes to allow capacitors to discharge before touching any internal parts of the equipment. Failure to observe these precautions could result in fatal injury.

Precautions When Working On Live Circuits

Stand on an insulating mat. Make a habit of using only one hand. Make sure that there is another person nearby in case emergency assistance is required.

Application of Equipment and Safety Devices

The adjustable speed drive and all components of the drive system, such as operator control devices, electrical power distribution equipment, the motor and mechanical power transmission equipment, must be properly selected and applied to assure a safe and reliable installation. Each individual installation has unique requirements for safety equipment such as emergency stop pushbuttons, pre-start alarms, motor and power disconnect devices and guards on mechanical power transmission apparatus. The party responsible for the overall design and operation of the facility must make sure that qualified personnel are employed to select and apply all components of the drive system including appropriate safety devices.

Hazard of personal injury or equipment damage exists if the drive and/or the driven machine are operated above their rated speed due to misadjustment or electronic failure. Be sure to consider this factor in selecting gear ratios and safety devices.

Always Wear Safety Glasses

Safety glasses should be worn by all personnel involved in installing or maintaining the equipment. This applies equally to all electrical and mechanical workers. Other safety clothing should be selected as appropriate to the task and work environment.

Handle With Care

Handle the equipment carefully to avoid personal injury or damage to the unit.

Provide Appropriate Guards Around Moving Parts

Before operating the equipment, make sure that appropriate guards and other safety devices are in place. Refer to OSHA rules and regulations, paragraph 1910.219 for guards on mechanical power transmission apparatus.

Observe Requirements of the National Electric Code

All wiring must be in accordance with the National Electrical Code (NEC) and/or other codes as required by the authority having jurisdiction. The electrical connections completed by the installer must conform to the instructions and diagrams supplied.

National Electric Code Article 430-102 requires a disconnecting means for each motor and controller located in sight from the motor, controller and driven machinery locations or capable of being locked in the open position if not located in sight. This disconnecting means is not included with the drive equipment unless specifically ordered.

Not for Use in Hazardous Locations

Unless specifically labelled as approved for such use, this equipment is not suitable for use in an explosive atmosphere or in a "Hazardous (Classified) Location" as defined in article 500 of the National Electrical Code.

Provide Adequate Ground Connections

For personnel safety and reliable equipment operation, firmly earth ground each piece of equipment as directed in this manual and shown on the connection diagrams provided. The ground conductor should be the same size as the incoming power wires or sized according to NEC table 250-95. A copper or aluminum conductor must be used. Grounded conduit connections are not adequate for use as equipment ground connections.

Instruction Material and Drawings

In addition to this manual, data sheets, drawings, supplementary instruction sheets and errata sheets may be included in the package of instruction material that is furnished for each drive. Be sure to save each of these items for future reference. The drawings and data included in this manual are generally representative of the product line, but do not accurately include every detail pertaining to specific equipment provided for an individual customer order. Drawings and data sheets which are identified by PRO/Serial number as pertaining to a specific piece of equipment take precedence over this manual. **Note:** The information furnished may not cover changes made to the equipment after shipment. **All data is subject to change without notice.**

Technical Assistance

It is usually best to request assistance from DSI/Dynamatic sales office or through your local Dynamatic distributor. To contact the sales office, call the customer service department at 1-800-548-2169 or visit our website www.drivesourceusa.com.

DANGER 115 VAC

This controller is connected to 115 Vac and many of the exposed components, leads and terminals are hot whenever the 115 Vac is connected. The controller "Stop" pushbutton does not remove power, but switches the controller output to the brake terminals B1 and B2. All other components are hot. Disconnect the incoming power when working on this controller.

Since above ground electrical potentials can be hazardous, all electrical work must conform to the National Electrical Codes and all local regulations. Properly ground the controller with a permanent ground wire to an earth ground terminal.

CAUTION

Refer to OSHA rules and regulations, paragraph 1910.219, for guards on mechanical power transmission apparatus. Only qualified maintenance personnel should work on this equipment, after having read these instructions. All instructions and procedures should be followed.

Important Notice

This manual includes the necessary instructions and drawings to cover the Installation, Operation and Maintenance of the Model 3000 controller. Make sure that the manual is read by those persons installing, operating and maintaining the equipment, and that each knows where the manual will be kept.

Table of Contents

| | |
|-------------------------------------|---|
| 1. General Information | |
| Safety | 1 |
| Warranty | 1 |
| Shipping and Receiving | 1 |
| Handling | 1 |
| Storage | 1 |
| Specifications | 1 |
| General Description | 1 |
| 2. Installation | |
| Location and Mounting | 2 |
| Enclosure Dimensions | 2 |
| Connection Diagrams | 3 |
| Wiring | 4 |
| Grounding and Cautions | 4 |
| Panel Mount Dimensions | 4 |
| 3. Start-Up and Adjustment | |
| Power OFF Checkout | 4 |
| Power ON Checkout | 5 |
| Adjustments - Speed Control | 5 |
| Adjustments - Voltage Control | 6 |
| Min Speed/Accel Rate Pots | 6 |
| Adjustment - Brake Voltage | 6 |
| 4. Operation | |
| General Theory of Operation | 6 |
| Protective Features | 6 |
| Abnormal Operation | 7 |
| 5. Maintenance | |
| Purpose | 7 |
| General Maintenance | 8 |
| Test Voltages | 8 |
| Renewal Parts and Service | 8 |

1. General Information

Safety

The Model 3000 controller is a small, simple, electronic controller. However, the installation, setup and maintenance should be performed by trained personnel skilled at working with electronic equipment. The electrical potentials inside the controller can be fatal if proper procedures are not followed. All warnings and cautions listed in the manual should be strictly observed. Labels are used in the controller to warn of potential hazards. Heed these labels and instruct others of their importance and meaning - a sample of a label used is as follows:

DANGER
115 VAC

This is a red label used to warn that dangerous voltages exist on exposed terminals.

Warranty

Eaton warrants this controller to be free from defects in material and workmanship for a specific time period, as stated in its published warranty policy in the Company's pricebook and in its Terms and Conditions of Sale printed on the back side of the order paperwork. Damage from shipment, handling, storage, misuse and abuse are not covered. If you believe a warranty claim exists, contact the local sales office or the Field Service Department. A copy of the warranty terms is available upon request.

Shipping and Receiving

Shipping damage and lost shipments are the responsibility of the carrier and are not covered by warranty. Therefore, it is essential that a careful inspection be made on receipt at your plant. Report damaged and missing items immediately to both the carrier and Eaton's local sales office. It is important that you file a claim with the carrier; this is your responsibility. Failure to file promptly may prevent collection for the loss.

Handling

Electronic circuits are easily damaged. Do not drop the printed circuit board (PCB), twist it or stack other items on top of it. Keep the PCB or controller wrapped and prevent abusive contact with protective padding.

Storage

When storing the controller or printed circuit board, keep it packaged as shipped. Store in a clean, dry location, protected from sudden temperature changes, shock, vibration, corrosive vapors and high humidity. Moisture must not condense on the board. Storage temperature must not exceed 60°C. (140°F.) or go below 0°C. (32°F.). Contact the Field Service Department when long time storage or other special conditions exist.

Specifications

Input Power - 115 Vac, +/-10%, single phase, 50/60 Hertz, 5 amps maximum.
Input Impedance - 2% line impedance is required. Isolation transformer should not be greater than 2kVA or have less than 2% secondary impedance to permit proper operation of the ground fault and short

circuit protection. A 750 VA isolation transformer is recommended.

Output Power - 0 to 90 Vdc, 0 to 4.3 amps
Operating Ambient - 0°C. (32°F.) to 45°C. (113°F.)
Humidity - 90% non-condensing maximum
Altitude - 1000M (3300 ft.) maximum without derating.

Model 3000 Controller

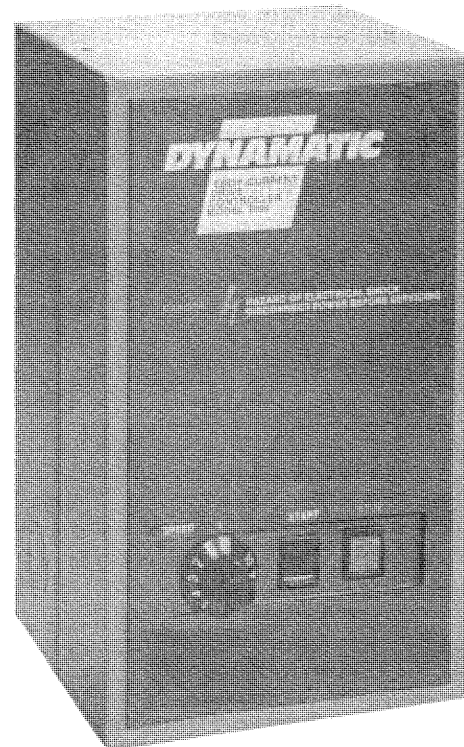

Figure 1

General Description

The Model 3000 Controller is a complete controller on one printed circuit board for use with eddy-current drives requiring 90 Vdc coil voltage up to 4.3 amps maximum. The controller will provide either speed control or voltage (torque) control, depending on the positioning of an on-board jumper. While this controller is not intended for modification, there are a number of standard features included:

- Linear Acceleration circuit, adjustable from 1 to 30 seconds.
- Stopping Brake circuit, adjustable for 0 to 90 Vdc.
- Speed or Voltage control, selected by on-board jumper.
- Min Speed, Max Speed and Damping adjustments.
- Input line transient spike suppression.
- Output short circuit and ground fault protection by fuses.
- Unattended start prevention by ac relay start circuit.

Specification Label

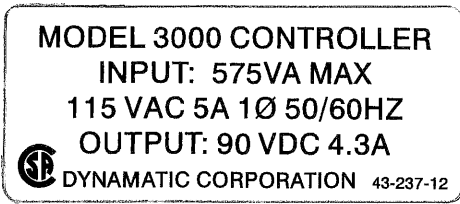

Figure 2

The printed circuit board is 5 x 6.88 inches. In the NEMA 1 enclosure version a bracket contains the operator elements, a potentiometer and two push-buttons. On the panel mount version, a terminal block is provided for the connection of remotely mounted operator elements. Due to the differences in the controller for NEMA 1 vs panel mounting there are two different control assemblies:

15-889-1, includes operator elements and enclosure.
15-888-1, panel mount without operator elements.

The NEMA 1 enclosure consists of a base, printed circuit board mounting plate and cover with a 3.75 x 1.25 inch opening through which the operator elements protrude. The enclosure is 5.63 inches wide, 9.50 inches high and 4.88 inches deep. Two pins at the top of the cover fit into holes in the base to secure the cover to the base. A slotted head, quarter turn fastener at the bottom of the cover locks the

NEMA 1 and Panel Mount Controllers

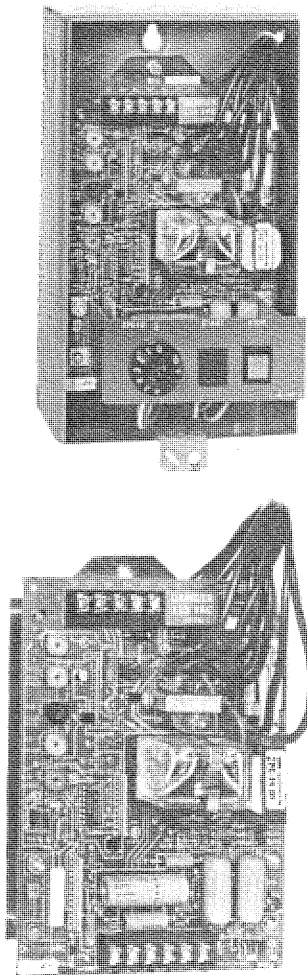

NEMA 1

Panel Mount

Figure 3

cover to the base. Holes are provided in the cover and base hasp for a padlock.

The printed circuit board is fastened to the mounting plate with four 6-32 screws. The mounting plate fits onto two screws at the bottom of the enclosure and is held in place by one 10-32 screw at the top center.

2. Installation

Location and Mounting

The basic consideration in selecting a location for mounting the controller is the environment. Locate the controller in an area where it will receive adequate ventilation and not be exposed to ambient temperatures above 45°C. or below 0°C., or be subjected to dirt, contaminants, water or corrosive vapors.

When mounting the NEMA 1 enclosure on or near the machine, select a flat surface, free of vibration and protected from accidental bumping by fork trucks and other material handling equipment. Refer to the enclosure dimension drawing and locate three holes as shown for 8-32 screws. Use round head screws of adequate length and lockwashers to prevent loosening.

NEMA 1 Enclosure Outline and Dimensions

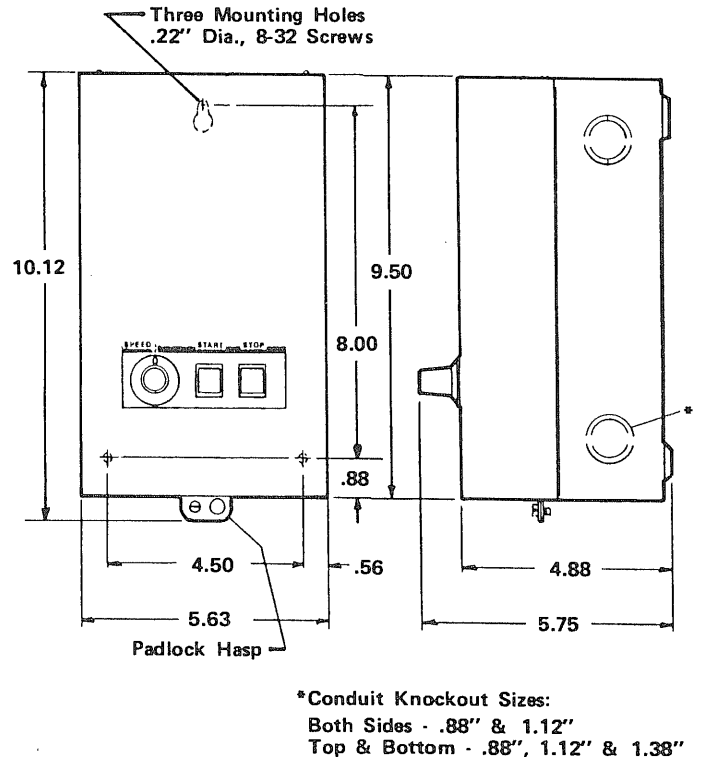

Figure 4

Panel mount controllers are mounted by means of three holes required for PCB bracket mounting, similar to the hole locations in the box. Refer to the dimension drawing and locate the three holes as shown. Be careful to locate the holes accurately, and use lockwashers under round head screws.

Connection Diagrams

Typical means of connecting the Model 3000 controller are shown on this page, Figures 5, 6, 7, and 8. If the line impedance is less than 2% provide a 1:1 isolation transformer with the proper impedance. (See Specifications on page 1 of this instruction manual). This transformer should be interlocked with the motor starter. A typical arrangement is shown in Figure 5.

If 115 volts is not available in the area of installation, the use of a step-down transformer will be required. The 2% impedance limitation must also be observed. See Figure 6 for a typical installation.

If the mechanical unit has been ordered and supplied with a transformer winding installed by the factory, see Figure 7 for a typical wiring installation.

Note the use of a disconnect device and motor starter in each situation.

Ref. Figure 8.

Connection Diagram

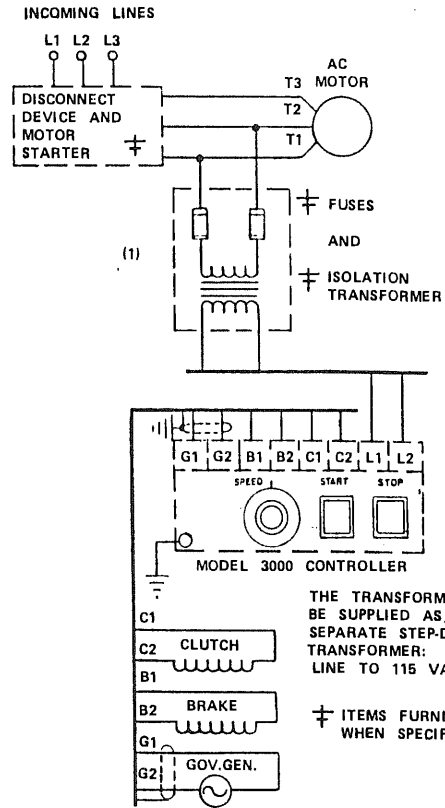

Figure 6

Connection Diagram

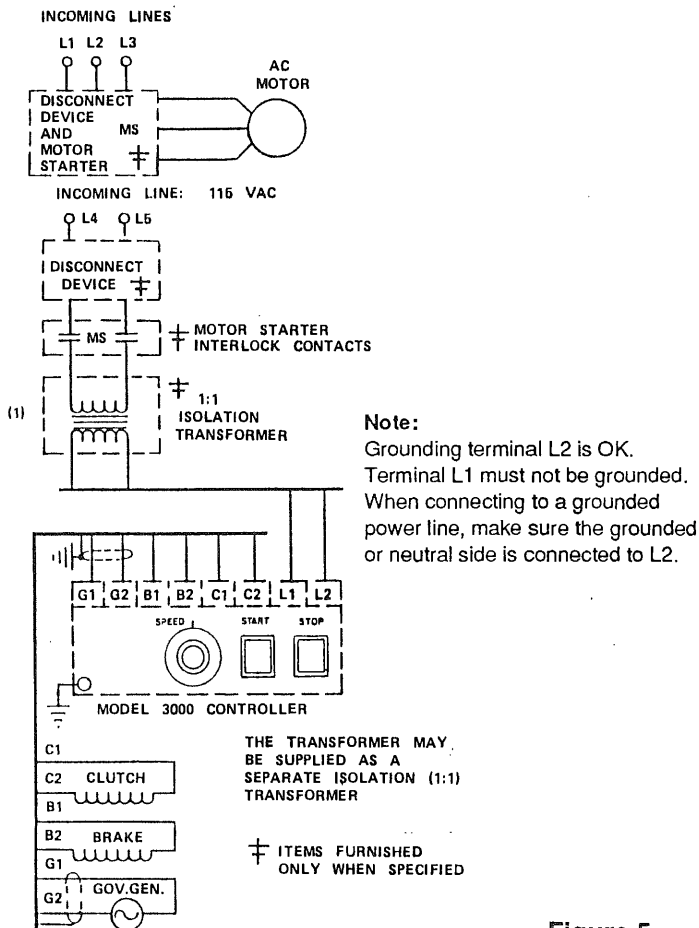

Figure 5

NOTES:

¹ When a separate power transformer is used, be sure to connect it between the motor and controller, or use motor starter interlocks, so that controller power is never on unless the motor is on.

² The center tap of the transformer winding of the ac motor is not used by the Model 3000 controller. This lead should be taped to prevent grounding.

Connection Diagram

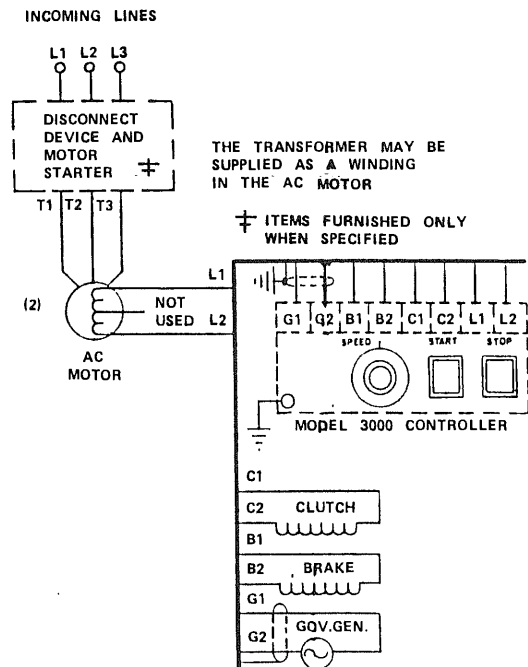

Figure 7

Connection Diagram

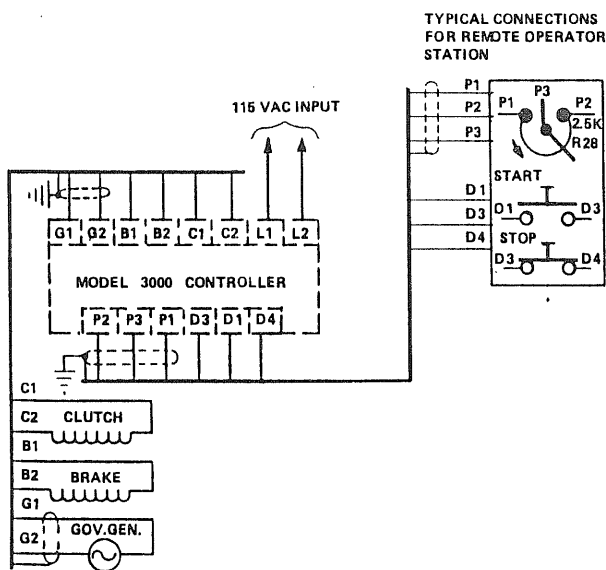

Figure 8

Wiring

Knockouts are provided in the enclosure base, 2 for 3/4-1" conduit, located in the center of the top and bottom. Ten 1/2-3/4" conduit knockouts are located as follows:

- (2) in the back of base at upper corners
- (2) in each side near the top
- (2) in each side near the bottom
- (2) in bottom on each side of 3/4-1" knockout
- (2) in top on each side of 3/4-1" knockout

Install conduit and wiring in accordance with the National Electrical Code, or Canadian Electric Code, and all local codes. Use stranded conductor as solid conductor is likely to fracture in time from vibration. Use minimum of 16 gauge copper wire for power wiring to terminals L1, L2, C1, C2, B1, B2 and for D1, D3 and D4 on panel mount controllers, unless code specifies larger wire size. Wiring from feedback generator to G1 and G2 and P1, P2 and P3 on panel mount controllers should be shielded cable with the shield grounded at one end only. Note, B1 and B2 are used only with units having a brake.

Grounding and Cautions - Enclosed Version Only

Firmly ground the controller from the ground terminal to earth ground. Use the same size wire as used for the incoming power to L1 and L2. Be careful not to ground any other points. The panel version need not be grounded.

CAUTION

Install a disconnect switch in the ac input power leads to disconnect the controller from the line, as shown in the connection diagrams - Figures 5, 6, 7, and 8. Refer to the applicable codes when selecting the type and size of disconnect for 5 amps at 115

Panel Mount Outline and Dimension

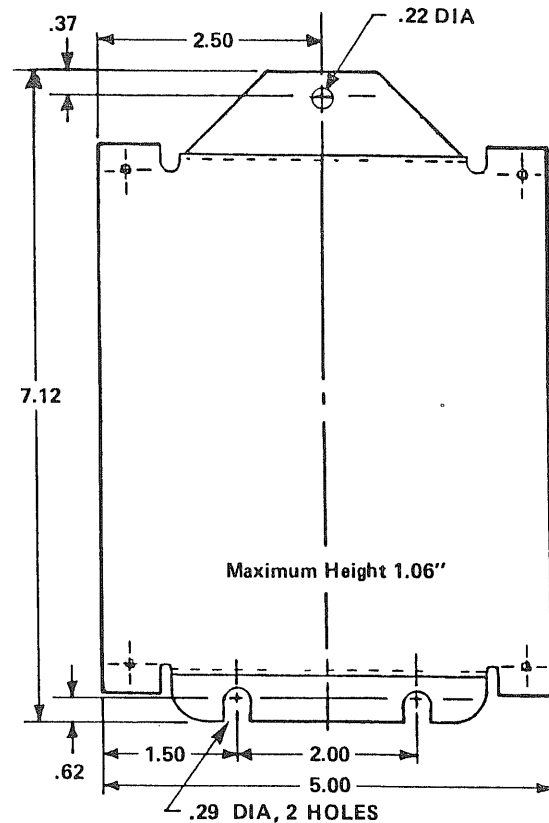

Figure 9

Vac. Provide a means for the operator to turn the power ON and OFF. We recommend interlocking the controller power with the ac motor.

CAUTION

Do not modify or add relays, solenoids or other electrical devices to the controller; the power supplies and foil runs are not sized for additional loads. The Speed potentiometer is 2 to 2.5K. If a remote Speed potentiometer is used with relay switching contacts, use two contacts per pot to open both the P2 and P3 leads. This controller will switch to zero whenever the Speed pot circuit is opened, or when high resistance contact is present. Do not install external switching between the clutch and brake coils and the controller.

3. Start-Up and Adjustment

Power OFF - Checkout

Before starting the controller or applying power, check the entire installation to make sure it is ready to start and that all personnel in the area have been alerted.

1. Inspect controller carefully for loose connections, broken wires, loose components or any signs of damage that may have occurred during installation.
2. Recheck the wiring, comparing the installation with the wiring diagram.
3. Recheck the drive unit to make sure it is ready to run and that its nameplate specifies coil voltage of 90 Vdc and amperage not greater than 4.3 amps.

Controller Grounding

15-888-1 Panel Mount Assembly

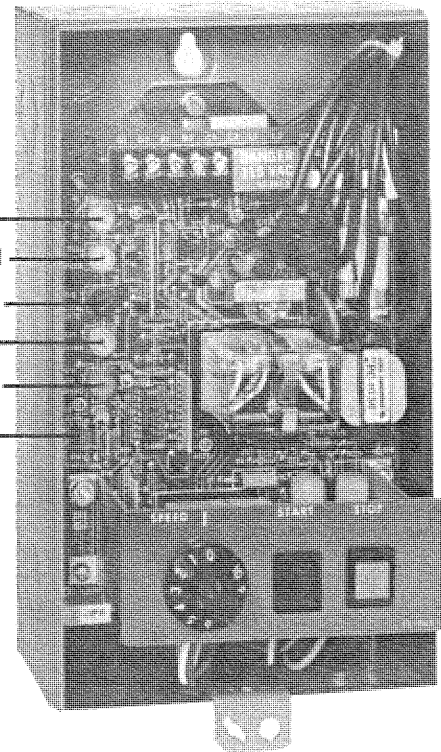
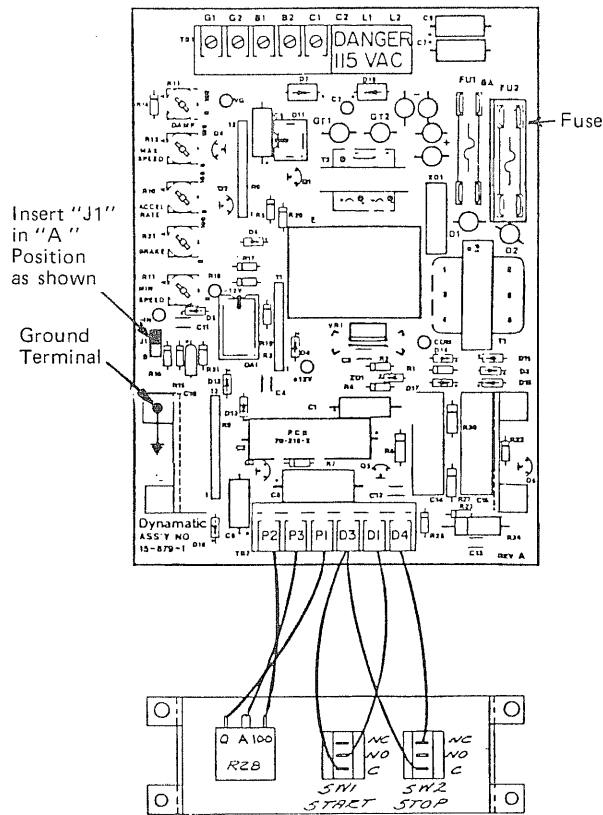

Figure 11

NOTE: The panel version need not be grounded.

Figure 10

4. Inspect the machine and drive train to make sure they are ready to operate and that no obstruction is present to cause damage.
5. Check to see that all guards are in place and that no electrical connections are exposed.
6. Verify that the incoming voltage is correct.

Power ON - Checkout

The Speed/Voltage jumper, located at the left edge of the controller below the row of five adjustment pots, must be in the proper position for voltage or speed control. To change position, pull the "blue" jumper off and re-install over the correct pins. Refer to Figure 11 for jumper replacement.

Speed - use pins A and center
Voltage - use pins B and center

1. Alert personnel in the area that start-up will begin.
Note - If controller is misadjusted (Min Speed) or miswired (Ref Pot), the drive could run when the Start pushbutton is pressed, even though Ref. pot is at zero.
2. Turn the Speed pot, R28, to zero, full CCW.
3. Start ac motor and make sure rotation is correct.
4. Turn ON 115 Vac to controller. Press Start pushbutton. E relay on controller should pull-in to connect controller output to clutch coil.
Caution: Shaft rotation may occur at this time.
5. Turn Speed pot, R28, slowly clockwise. Drive should begin to run. If drive and machine run properly proceed with adjustment. If not, correct any deficiency. If drive does not run, turn to Maintenance section.

Adjustments - Speed Control

CAUTION - Controller is hot whenever 115 Vac is ON. Controller Stop pushbutton does not remove 115 Vac.

A load is needed to adjust controller. Connect a dc voltmeter across C1(-) and C2 (+) and leave it connected for the first three adjustments. Normally, max voltage will be 85 - 95 Vdc.

Min Speed - Set Run Speed pot, R28, at zero, (full CCW), and start controller. Ac motor should be running. Turn Min Speed pot, R11, CW until a meter reading is detected. Then, turn back to zero reading. If some value of minimum speed is required turn Min. Speed pot, R11, CW until the desired speed is obtained.

Max Speed - Set Run Speed pot, R28, at 100%, full CW and allow drive to accelerate to full speed. Turn Max Speed pot, R12, CW until meter indicates maximum output. Then, turn back until voltage just begins to decrease. If some lower max speed is required, turn Max Speed pot, R12, CCW until desired max speed is reached.

Damping - Set Run Speed pot, R28, at 50% and allow drive to reach set speed. Turn Damping potentiometer, R13, CCW until drive oscillates. It may be necessary to try various loads to observe oscillations. Increase CW until oscillations stop. This setting should be as low as possible (CCW). If set too high, the drive may act sluggish.

Stop controller using Stop pushbutton. Remove meter and reconnect for 50 Vac across G1 and G2. Drive should be stopped. Next adjust Accel Rate.

Accel Rate - Full CW = 1 sec. and full CCW = 30 sec. Set Run Speed pot, R28, to 100% (CW). Press Start pushbutton and time drive acceleration from stop to

full speed. Meter will indicate drive speed. Adjust Accel Rate potentiometer, R10, and repeat cycle, timing drive acceleration from stop to full speed. Repeat until desired time is reached. Remove meter.

Adjustments - Voltage Control

Return to section Power ON - Checkout, and perform steps 1-5 after first placing the "blue" jumper in the voltage position, using pins B and center.

CAUTION - Controller is hot whenever 115 Vac is ON. Controller Stop pushbutton does not remove 115 Vac.

Connect a dc voltmeter, 100 Vdc scale, across C1(-) and C2(+) and leave connected for the adjustments.

Min. Speed - Set Run Speed potentiometer, R28, at zero, full CCW and start controller. Ac motor does not need to be running. Turn Min Speed potentiometer, R11, CW until a meter reading is detected. Then turn back to a zero reading. If some level of voltage is required at zero Run Speed pot setting, turn Min Speed pot, R11, CW until desired voltage is obtained.

Accel Rate - Full CW = 1 sec. and full CCW = 30 sec. Press Stop pushbutton. Wait until voltage has decayed to zero. Set Run Speed pot, R28, at 100% (CW). Press Start pushbutton and time voltage increase to maximum. Adjust Accel Rate and repeat timing sequence until the desired time is obtained.

Note - Max Speed and Damping potentiometers are not used in voltage control mode. Remove meter and proceed with brake adjustment, if used.

Min Speed/Accel Rate Pots

If Min Speed pot, R11, and Accel Rate pot, R10, are both preset at some CW setting when the controller is first turned on, the speed of the mechanical unit will quickly jump to the speed set by the Min Speed pot. If Speed pot, R28, is preset above the Min Speed, the speed of the mechanical unit will then increase linearly between the Min Speed and Run Speed settings.

If this jump between zero and the Min Speed setting is unsatisfactory to the application, the Min Speed pot, R11, should be adjusted for a zero reading and the speed pot wired as shown in Figure 12 with a separate Min Speed pot or fixed Min Speed resistor and relay to produce a fully linear ramp from zero to the desired Run Speed. The total series resistance of the two pots or pot and resistor should be between 2,000 and 2,500 ohms. The relay should be deenergized for Min Speed and energized above Min Speed. The relay (Part No. 53-133-0) and socket (65-45-1) can be purchased from the factory.

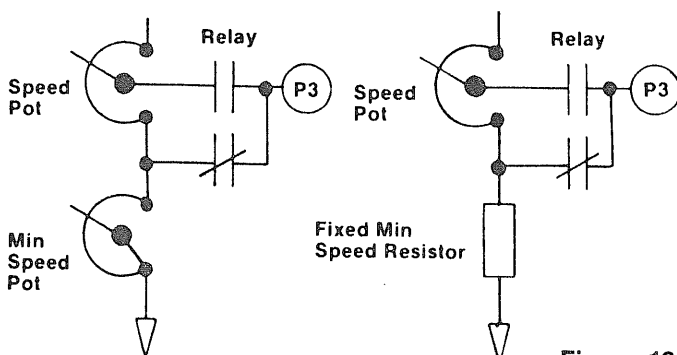

Figure 12

Adjustment-Brake Voltage

Full brake voltage (90 Vdc) is obtained when the Brake potentiometer, R21, is set at 100%, full CW. Brake voltage is present at terminals B1 and B2 whenever 115 Vac is applied and the controller is in the Stop mode. Softer braking is obtained by turning the Brake potentiometer CCW. This adjustment can be made by observing braking action or by connecting a dc voltmeter across B1(-) and B2(+), on the 100 Vdc scale, and adjusting for a specific voltage.

4. Operation

General Theory of Operation

The Model 3000 controller is a basic Speed controller intended for use with Dynamatic Adjusto-Speede® drives. Start and Stop pushbuttons and a Speed setting potentiometer are required to start and stop the drive and to set desired speed. The controller will, in the Start mode, provide power to the eddy-current clutch to control speed. By measuring the actual shaft speed, the controller will vary its output to maintain the speed setting. The accuracy, or regulation, will be within 0.5% of maximum speed with a 75% load change from 25% to 100%. For example, assume the drive has a maximum speed of 1700 rpm (0.5% is 8.5 rpm). At any speed above minimum speed (usually 50 rpm) the drive will slow down as load is added. If the speed is at 1000 rpm with 25% load, as load is increased to 100%, the speed will reduce no more than 8.5 rpm and the output would then be running at 991.5 rpm. As load is removed the speed would increase again. The operator always has the option to reset the speed to regain the slight regulation droop.

The alternate mode of operation is called Voltage Control and is intended to control output torque from the drive. An internal jumper change is required to obtain this mode of operation. Once set, the operator will be able to start and stop the drive and to set output torque. This mode of operation will not control speed. The drive will run as fast as the machine allows, providing the torque as set by the operator. If load decreases the drive will speed up. Added load will slow down the drive. However, the amount of output torque will remain relatively constant, dependent on the torque vs voltage characteristics of the drive. This type of controller is typically used as a second or helper drive on a line shaft driven machine and on certain types of winders and takeups.

Protective Features

A number of protective features have been included in the design of the Model 3000 controller which the operator should know and understand.

Unattended Start Prevention - An on-board relay is included to prevent the controller from starting without first pressing the Start pushbutton. The Start button energizes the relay, which then holds itself ON. If the Stop button is pressed or power fails momentarily, the relay drops out and the clutch is disconnected from the controller. If a brake is included, the relay connects the brake to stop the machine. However, if power remains OFF, there will be no brake action and the machine will coast to a stop. When power comes on again, the controller will not restart until the Start button is pressed.

Loss of Reference Protection - A buffer circuit is used to control the controller output whenever the Run Speed pot circuit opens. For example, the pot may be damaged or the connection broken. The buffer circuit senses this loss of reference and switches the controller to zero output until the circuit is restored. This circuit minimizes a possible run-away condition.

Transient Suppression - In many industrial plants, switching power devices ON and OFF creates power line disturbances, which show up as spikes on the ac waveform. The controller has a suppressor across its input to absorb transient spikes and surges to protect the controller from damage.

Short Circuit Protection - Two fuses in the 115 Vac input protect the controller from short circuits. When a short occurs, the fuses will blow, causing the controller to shut down from loss of power. The short must be cleared and new fuses installed to begin running again.

Acceleration Circuit - An adjustable rate circuit is included to allow the drive to accelerate slowly, reducing shock and sudden speed changes. This circuit is adjustable from 1 to 30 seconds and should be set to provide the type of operation required. This means that the Run Speed pot can be preset to some desired speed or left as it was set previously. When pressing the Start pushbutton, the acceleration circuit will cause the machine to accelerate slowly to the set speed.

Abnormal Operation

The operator should become familiar with normal operation of the machine, drive and controller. Any abnormality should be reported so that corrective action can be taken. Noise, vibration and any change

in the way the controller responds can be an indication of impending breakdown. Failure to report this condition may allow a potentially hazardous situation to exist.

The operator should also be aware of other potential problems and take action whenever they are observed. The following are examples to be avoided:

1. Do not wash down or spray water on electrical equipment, either with power ON or OFF. If observed, do not start the machine, but alert maintenance personnel.
2. Do not allow debris, dirt, trim stock or any other foreign material to accumulate on or around the drive and controller equipment.
3. Do not hang coat or jacket over, or in any way cover, the controller. Also, do not block passage way to the controller that would prevent or impede access to the Stop button.

5. Maintenance

Purpose

The intent of these instructions is to assist qualified electronic maintenance personnel in identifying when a controller is not functioning properly and to make adjustments and minor repairs to it. We do not recommend printed circuit board repair at the component level. Too often, the repair is not complete and a latent defect remains to cause further downtime and possible hazardous conditions. The factory maintains a Repair Department, where returned boards are rebuilt to original specifications and each component is ATE tested to ensure compliance with test specifications.

Block Diagram of a 90 Vdc 3000 Controller

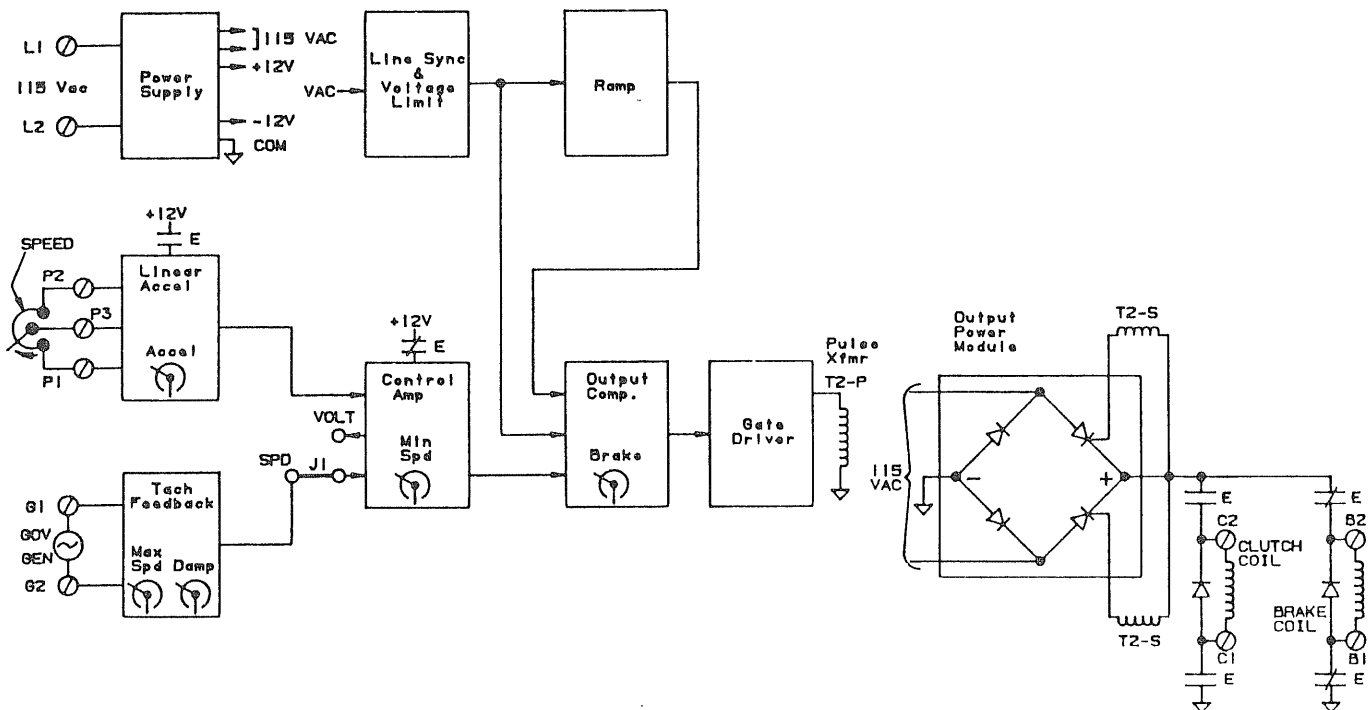

15-879-1 PCB Assembly

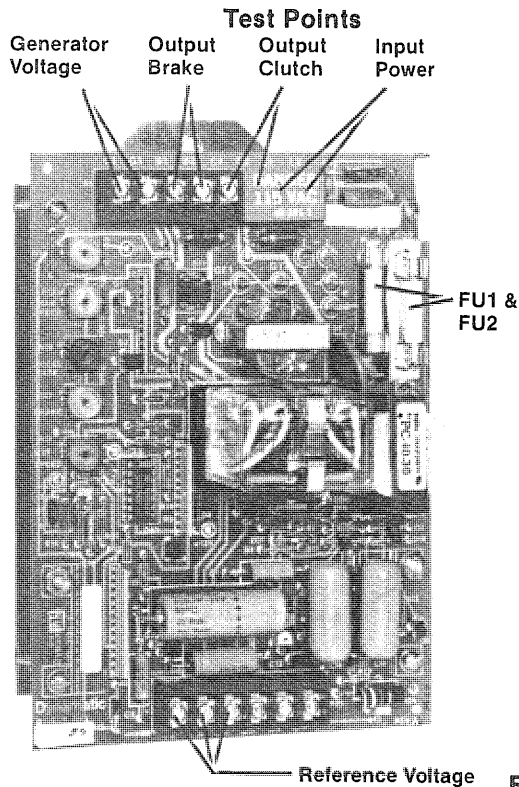

Figure 14

General Maintenance

It is important to keep the controller clean to allow proper heat dissipation and to prevent short circuits between components and foil paths. In addition, occasionally check for loose terminal or mounting screws. The fuses, relay and Run Speed pot are the most likely failure items. Since the controller is low cost, a spare should be kept on hand, as replacement may be less expensive than trying to identify and change failed components.

When taking voltage readings, be careful to place meter probes at the correct points. A slip or wrong placement may cause a short. Since voltage readings must be taken with the 115 Vac ON, remember the hazards involved to yourself and to the machine. When 115 Vac is ON, the controller is hot, even when the Stop button is depressed.

Test Voltages

The following test voltages and locations are provided to assist in troubleshooting and to help identify a malfunctioning controller. A voltmeter is required.

- Input Power** — 115 Vac should be present at terminals L1 and L2.
- Fuses** — 115 Vac at bottom of FU1 and FU2. If in doubt, turn off input power, remove fuses and check continuity.
- Output, Brake** — Up to 90 Vdc should be present at terminals B1 (-) and B2 (+) when the controller has 115 Vac applied and is in the Stop mode. If no voltage is present, adjust Brake Adjust pot, R21, CW. If 90 Vdc is not present when pot is at 100% CW controller is defective.
- Reference Voltage** — 8.5 Vdc should be present across terminals P2 (+) and P1 (-).

Note: Voltage is present only in the Start mode. Measure across P3 (+) and P1 (-) to check the Speed pot. The voltage should be 0V when the pot is fully CCW and +8.5 Vdc when pot is at 100%.

- Output, Clutch** — Up to 90 Vdc should be present at terminals C1(-) and C2(+) when controller has 115 Vac applied and is in the Start mode. Connect the meter across C1 and C2 and press the Start pushbutton. Turn the Run Speed pot, R28, to 100% (CW) and observe meter. Voltage should appear and drive should accelerate. With J1 jumper in the Speed position, max output should be obtained by slowly turning Max Speed, R12, to 100% (CW). When J1 is in the voltage position, full output should be obtained after the acceleration period. The controller is defective when full voltage cannot be obtained.
- Generator Input** — Up to 60 Vac possible. Connect ac voltmeter to terminals G1 and G2. Start and run drive to full speed. Measure voltage, which should be approximately 45 Vac at full speed. This voltage is necessary if the controller is used for Speed control. If the voltage is not present, refer to the drive instruction manual.

Renewal Parts and Service

Since the Model 3000 controller is a small, on the shelf electronic controller, failure will be handled by replacement. To minimize lead time and your resulting downtime, we recommend you stock one of each the following spare parts, as applicable. (Your basic printed circuit board number is determined by the controller model you have purchased):

15-879-1 PCB Assembly Only - Without SCR Power Mod and RL Latching Resistor
15-888-1 Panel Mount Assembly

Speed pot No. 49-355-252 (2.5K ohms)
Fuse No. 32-28-6091 (6 amp, 250V)

The company maintains a Repair Service Department that works on a time and material basis. Controller printed circuit boards returned for repair will be replaced through the exchange program. However, the Company will not accept replacement boards that are cracked, foil damaged or burned. All replacement boards or assemblies will carry a new factory warranty.

Technical assistance is always available over the telephone. Contact us at (800) 548-2169

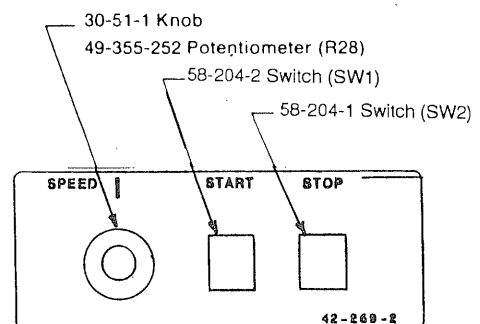

Figure 15

1-800-548-2169
sales@dynamatic.com



7900 Durand Avenue, Bldg. 3
Sturtevant, WI, 53177